

1st of March 2016
Horní Bečva



How to Present

We want to make decisions
about our town with you



Erasmus+

This project is co-financed by the European Union

MĚSTO KOPŘIVNICE



- **Introduction**
- **Presentation versus facilitation**
- **Topic, why and for whom**
- **Presenter's preparation**
- **What to watch for**
- **Mistakes, tips and hints**
- **Conclusion**



místní Agenda 21



Presenting

Facilitating

Introducing

Performing

First Impression

1. Funky / rock
2. Sea / mountains
3. Born before 1990 / after 1990
4. Vegetarian / eating meat
5. To have children / to don't have children
6. Married / single
7. Chinchilla / brown rat
8. Own house / mum, dad
9. Beer / wine
10. Red / orange



- **Introduction**
- **Presentation versus facilitation**
- **Topic, why and for whom**
- **Presenter's preparation**
- **What to watch for**
- **Mistakes, tips and hints**
- **Conclusion**



místní Agenda 21

PRESENTATION

Presentation of something
Demonstration of goods
Explanation of a topic



FACILITATION

Holding / guiding a discussion

MANIPULATION

Facilitator holds discussion, watches for imaginary borders, and mitigates potential conflicts





- **Introduction**
- **Presentation versus facilitation**
- **Topic, why and for whom**
- **Presenter's preparation**
- **What to watch for**
- **Mistakes, tips and hints**
- **Conclusion**



místní Agenda 21

Topic, why and for whom

KOPRIVNICE

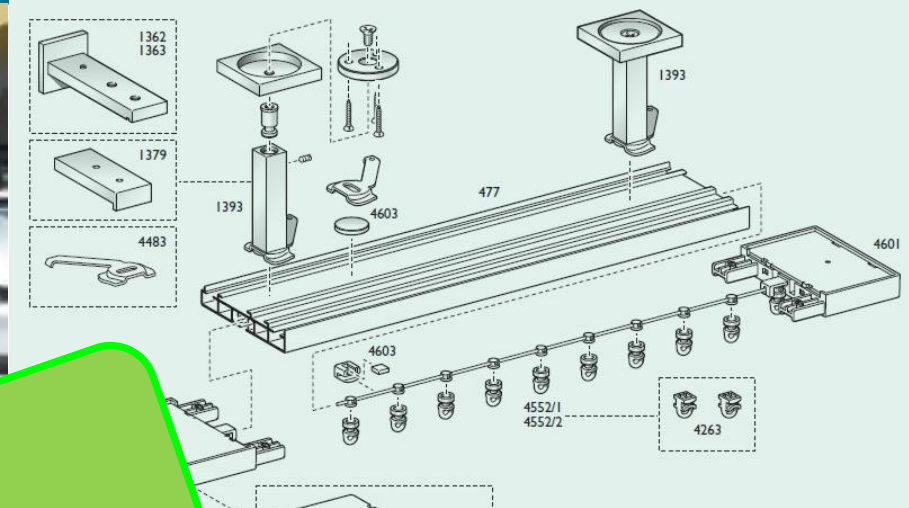

TOPIC



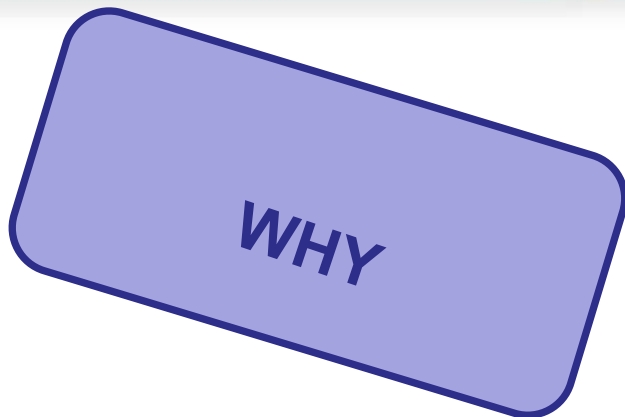

WHAT DO I WANT?

- To inform



**TALLONE STATHAM LI LUNDGREN NORRIS CREWS COUTURE
HEMSWORTH ALSO VAN DAMME WITH WILLIS AND SCHWARZENEGGER**



Topic, why and for

Anketní lístek Sportovního zařízení

► Zaznamenali jste, že se teplota vody:

a) ve velkém bazénu zvýšila o více než 1 stupeň Celsia?

ANO

NE

NEVÍM, nebyl(a) jsem v něm

b) v malém bazénu zvýšila o více než 1 stupeň Celsia?

ANO

NE

NEVÍM, nebyl(a) jsem v něm

c) ve vířivce zvýšila o 1 stupeň Celsia?

ANO

NE

NEVÍM, nebyl(a) jsem v ní

► Jste ochotni za větší komfort v bazénu zaplatit vstupné vyšší o 10 až 15 Kč za 1 hodinu pro dospělého, s možností využití vířivky a cenově upravených balíčků pro rodiny s dětmi, seniory a studenty?

ANO

NE

► Jste pravidelným návštěvníkem krytého plaveckého bazénu?

ANO

NE

► Vaše náměty pro lepší fungování krytého plaveckého bazénu:

► Vaše jméno a příjmení (pokud chcete):

Otázky:

1) Co u nás v restauraci oceňujete nejvíce?

2) Co v naší restauraci naopak postrádáte? Co byste doporučili zlepšit?

3) Uvítali byste nějakou změnu v jídelním lístku? Jakou?

4) Co máte u nás nejraději (uveďte pokrm či nápoj)?

Na závěr prosíme o několik informací o Vás:

Jste muž žena

Váš věk

do 18 18-26 27-40 41-55 nad 55

Jak dlouho jste zákazníkem restaurace Dock House?

jsem zde poprvé méně než 1 rok 1-3 roky

3-5 let více než 5 let

Váš e-mail (účast v soutěži):

Zasílat info o akcích (cca 1x měsíčně):

ano ne ne, již jsem zaregistrovaná/ý

Děkujeme za váš čas!

Vyplněný dotazník, prosíme, vložte do schránky v chodbě u toalet.

Můžete jej případně také zaslat naskenovaný e-mailem na adresu: info@dockhouse.cz. Dotazník ke stažení také na www.dockhouse.cz.

Topic, why and for whom



Topic, why and for whom

KOPRIVNICE

FOR WHOM



You are a founder member of the Children's Municipal Council of Myszkow.

Task: Step before the city management and convince them that it is a good idea to establish a Children's Municipal Council in the city.

Who, where, when, how, what, why, with whom,...

What does its work consist in?



místní Agenda 21

- Introduction
- Presentation versus facilitation
- **Topic, why and for whom**
- Preparation of the presenter
- What to watch for
- Mistakes, tips and hints
- Conclusion

Method, schedule, ...

- **Mental**
- **Related to content**
- **Visual**

- **Mental**

Topic, why and for whom

Main points - structure

Trial - family, friends, colleagues



!! STAGE FRIGHT !!



NICE

- **Related to content**

Do not forget ... topics, why and for whom

[Pictures, videos, hypertext links...](#)

Point of reference, slide, topic

- Introduction = mentioning whatever is related to the topic
- Content = points - never the whole text or sentences
- Conclusion = what did I say, max. 5 sentences

- **Mental**
- **Related to content**
- **Visual**





- **Presenter's Appearance**

Space

Importance of action

Who do I present for

Clothes ... colour?

Hairstyle

Make-up







KOPRIVNICE



STO KOPŘ

- **Readiness of the Presenter**

- Impression of the presentation depends on the readiness of the presenter
- Crisis Situations – equipment failure, voice indisposition, sudden “accidents“
- NEVER read from the screen
- Know the topics and issues related to it as much as possible in case of additional questions

You are a founder member of the Children's Municipal Council of Myszkow.

Task: Step before the city management and convince them that it is a good idea to establish a Children's Municipal Council in the city.

Who, where, when, how, what, why, with whom,...

What does its work consist in?



- **Introduction**
- **Presentation versus facilitation**
- **Topic, why and for whom**
- **Presenter's preparation**
- **What to watch for**
- **Mistakes, tips and hints**
- **Conclusion**



místní Agenda 21

First impression

1. Funky / rock
2. Sea / mountains
3. Born before 1990 / after 1990
4. Vegetarian / eating meat
5. To have children / to don't have children
6. Married / Single
7. Chinchilla / brown rat
8. Own house / mum, dad
9. Beer / wine
10. Red / orange

1. Impression – ??? seconds

Gentle smile
No excessive gesturing
Personal space!
Show interest

Private circles

Extrovert / introvert
??? m
Shaking hands



Profimedia.cz



Posture

Turn to your listeners
Shoulders
Tips of your toes

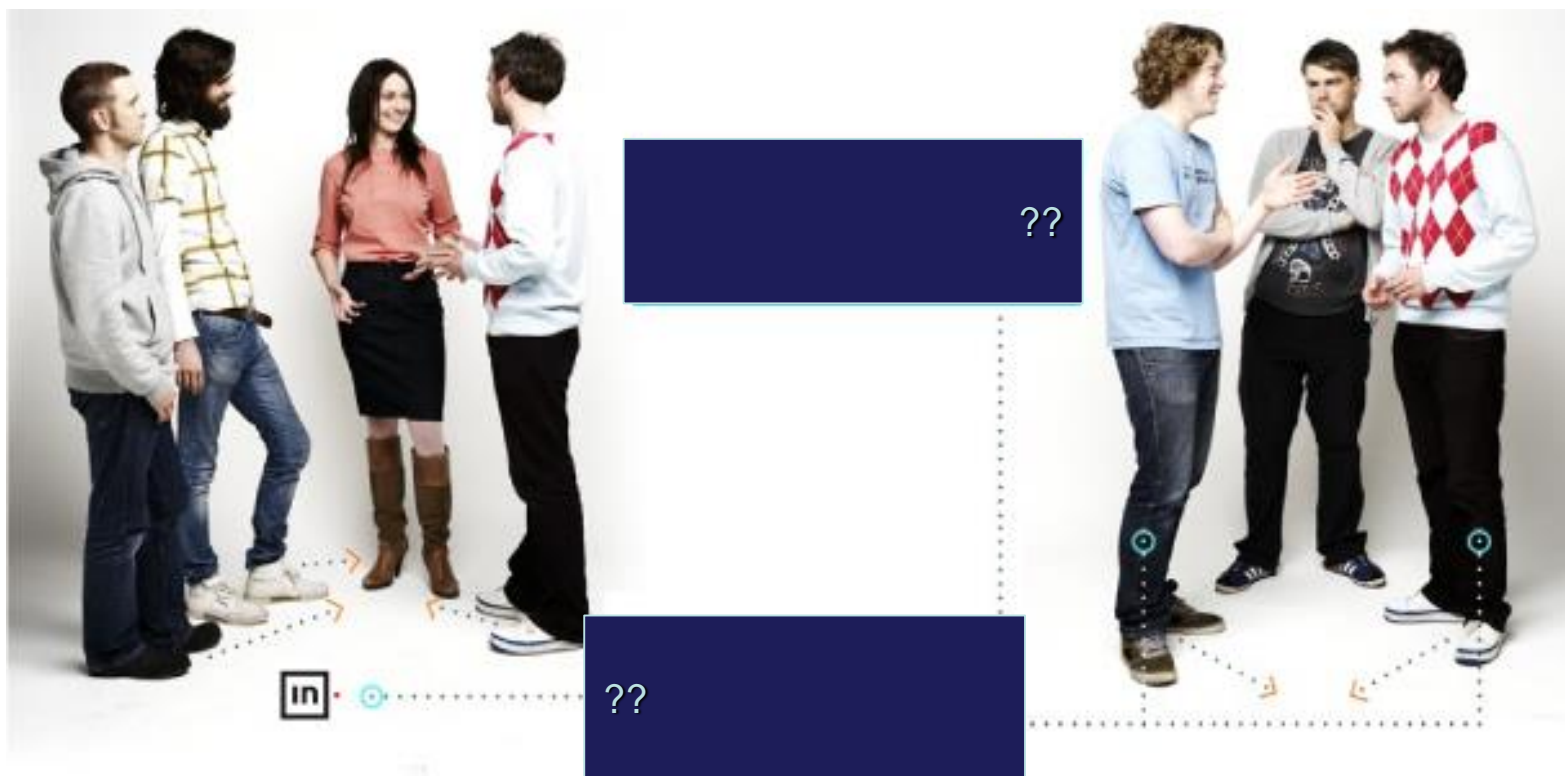

Hands

To see
Shaking hands
Fingers by your lips!!!

Lie

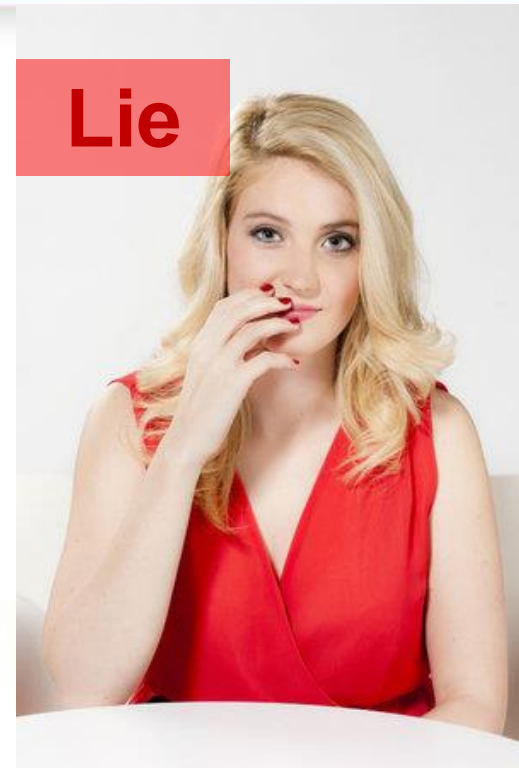

Thinking



Unease, fear





**Timidity,
shyness,
timorousness**



**Self-
confidence**



**Slight
annoyance**

Your Look

3 s

My look is convincing
Do not look at the ceiling
Increased frequency



Smile

Certainty
Infectiousness
Teeth baring!!!



Voice

Physiology
Men/women
Loudness
Positions - hmmm

Communication with Listeners



Dont's

Lack of breath

Tips and Hints



Dont's

Lack of breath

Not ending sentences

So, emm, hm...

Controlling your voice

Tips and Hints

Shakespeare

Structure, points, phrasing

1, 2, 3 ... hello

OUVEX DOWGLI

It is not possible to prepare 😊

Thank you for your attention

Ivana Rašková



Erasmus+

This project is co-financed by the European Union



místní Agenda 21

